

General Description:

The TMR9112 demo board was developed to support evaluation of the TMR9112 single-axis sensor. The demo board comes with the fast bipolar current pulsing circuit needed for initialising the TMR9112 sensor, and it can be powered from a USB port or any external 5V power supply. For user convenience, the demo board has an optional on-board timer clock with four selectable frequency settings. The On-board timer clock and frequency output can be enabled using the jumper pins. This demo board is divisible along the dotted line so that the sensor board can be separated from the pulsing circuit board.

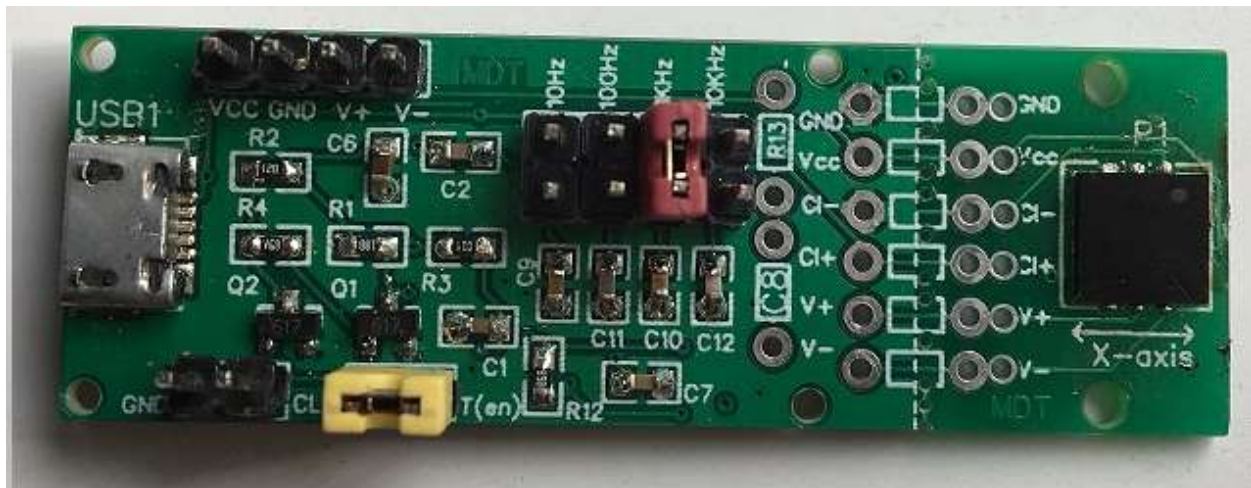

Features:

- Operate using 5 Volt external supply or through USB port.
- On board timer clock with four selectable frequency options.
- Bipolar fast current pulsing circuit and Voltage tripler circuit.
- Clock Input signal can be 3.3V or 5V logic.
- Demo board can be split along the dotted line to separate the sensor from the pulse electronics board

Pin descriptions:

Pin Name	Description
Vcc	Positive power supply
GND	Ground
V+ and V-	Differential output from the sensor
CLK	Clock input
T(en)	On board Timer output enable
C8, R18	Through hole pads for adding low pass filter resistor and capacitor for user selectable filtering.

Schematic Diagram:

Figure. 1

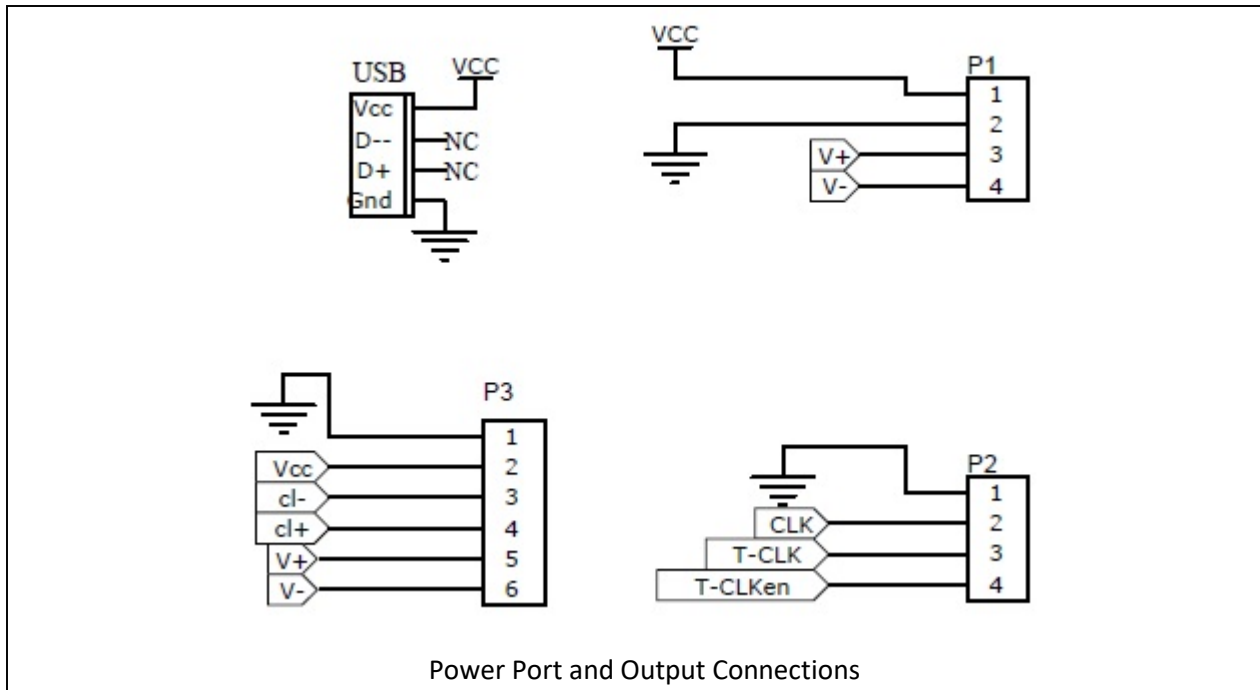

Figure. 2

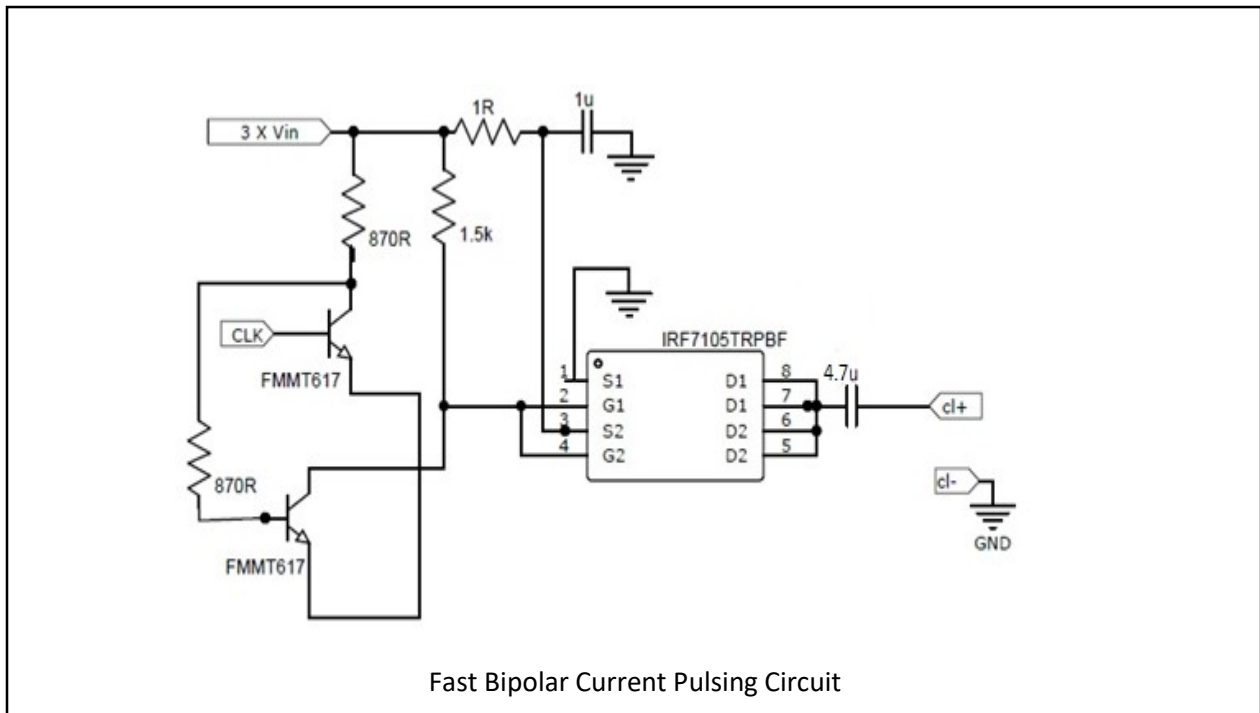

Figure. 3

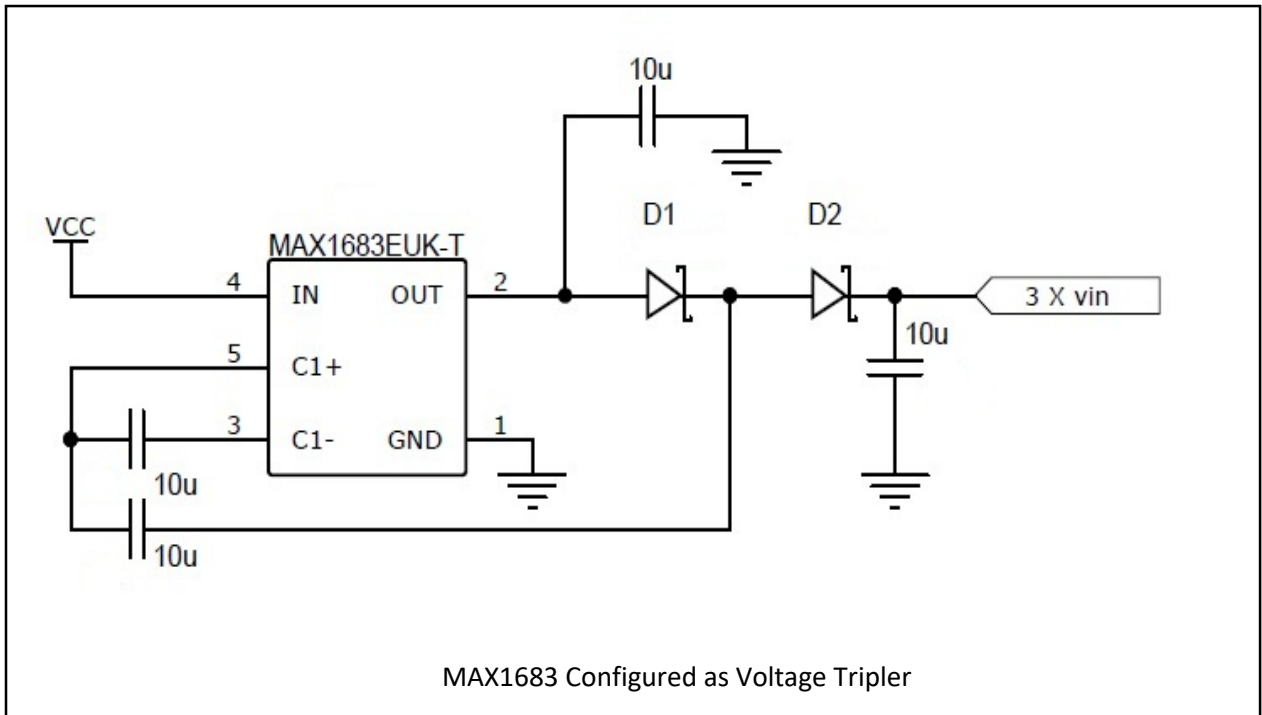
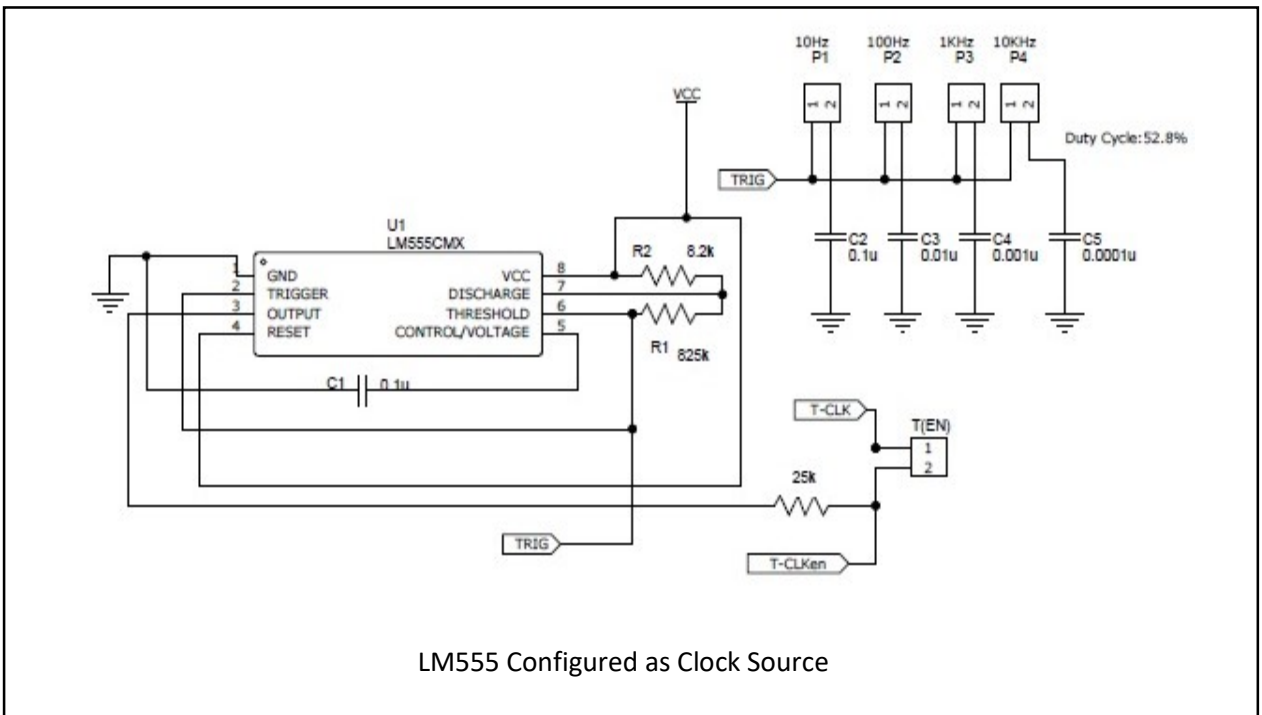

Figure. 4



Interfacing the TMR9112 Single-Axis Demo Board:

The diagram below illustrates a method to interface the TMR9112 demo board with data acquisition equipment. The sensor output can be read with the on-board timer enabled or from using external waveform to initialize the sensor on demand or as needed based on a user's custom algorithm.

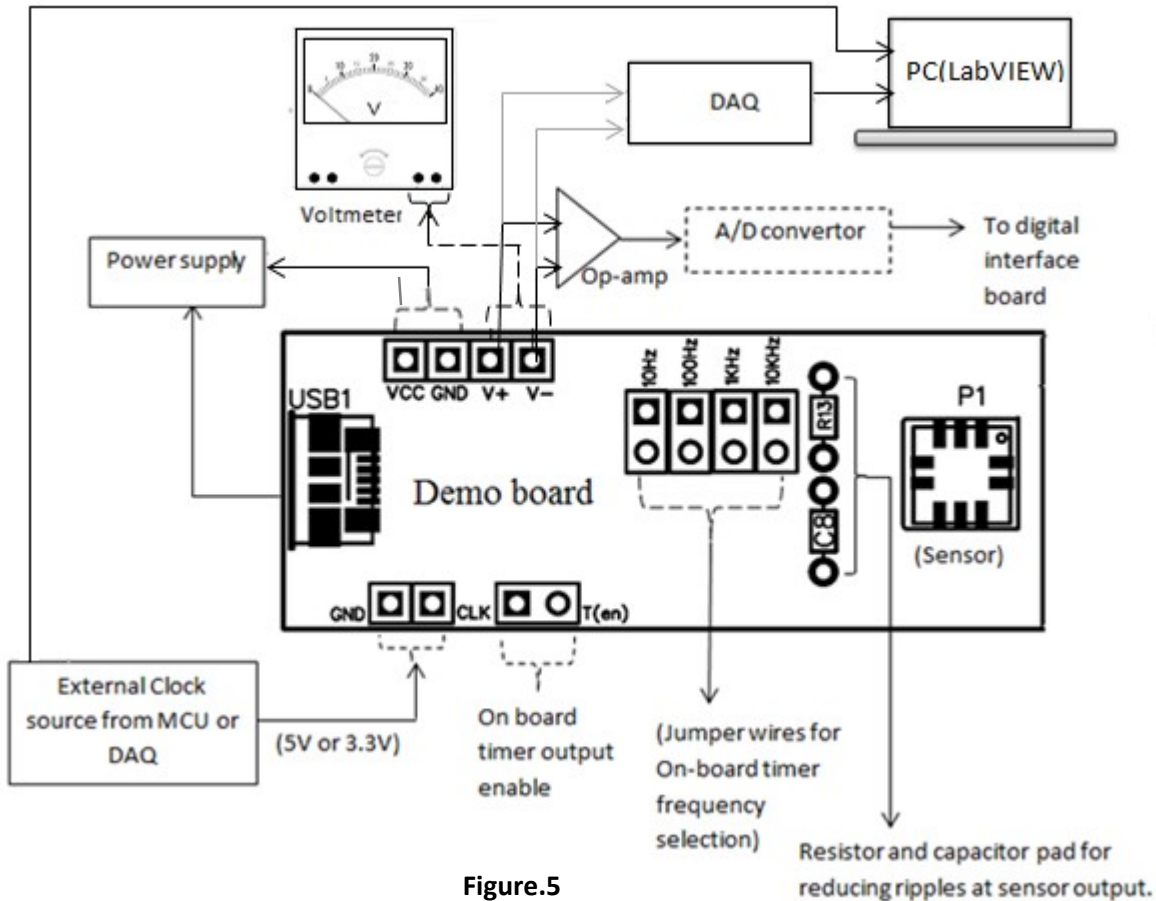

Figure.5

Resistor and capacitor pad for reducing ripples at sensor output.

1. Using a Continuous Pulse from the On-board Timer:

To enable the On-board timer, place the jumper pin onto the "T-en" terminal pins. Additionally select the appropriate frequency output, by placing a jumper onto the desired labeled frequency pins. The duty cycle of the timer output is roughly 52.3%. The sensor output at V+ and V- is the analog output, with reduction of unwanted hysteresis. Some residual high frequency ripple may appear in this output, and to remove its high harmonic content from the sensor output, a resistor and Capacitor should be added at the R18 and C8 through hole pads. The cut off frequency(f_c) must be chosen with respect to the pulse width, but a good rule of thumb would be to set it at clock freq(f_p), $f_p > 5 f_c$, where $f_c = 1/2\pi RC$.

2. Using a Timing Pulse from an MCU or External Clock Source:

An external timing pulse is often more efficient in terms of power efficiency and further hysteresis reduction. The timing cycle for one possible clock input and sensor read is shown in the figure below.

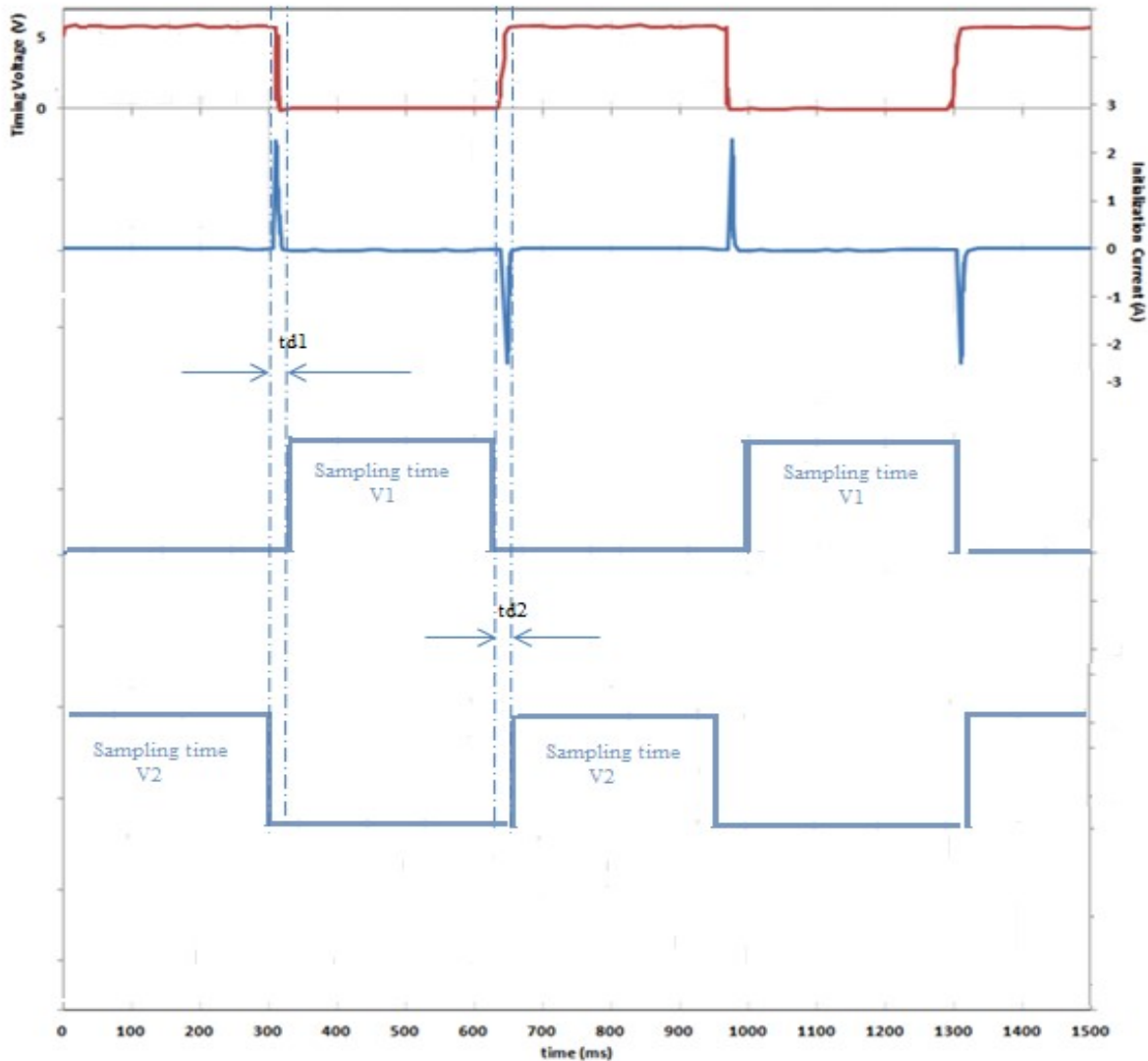

Figure.6

The ideal clock input waveform should be held high, and when the clock input goes LOW , a positive current pulse will be induced in the sensor initialization coil and negative current pulse will be induced when the clock input goes HIGH. The sensor value V1 should be sampled after the completion of positive current pulse with the time delay td1 and sensor value V2 should be sampled after the completion of negative current pulse followed by the time delay td2. The final sensor output V, should be calculated as, $V = (V1 + V2) / 2$.

Electrical Specification:

Tested at room temperature, $T=25^{\circ}\text{C}$.

Parameters	Min	Typ	Max	Units
Supply voltage	4.5	5	5.5	V
Supply current				
Without using pulse	--	--	27	mA
1. Clock freq=1Hz	--	--	32	mA
2. Clock freq $\leq 10\text{H}$	--	--	45	mA
3. Clock freq $>10\text{Hz}<100\text{Hz}$	--	--	163	mA
4. Clock freq $>100\text{Hz}<1\text{KHz}$	--	--	187	mA
5. Clock freq $>1\text{KHz}<10\text{KHz}$	--	--	190	mA
Clock Input	3.3	5	Vcc	V

Mechanical Dimensions:

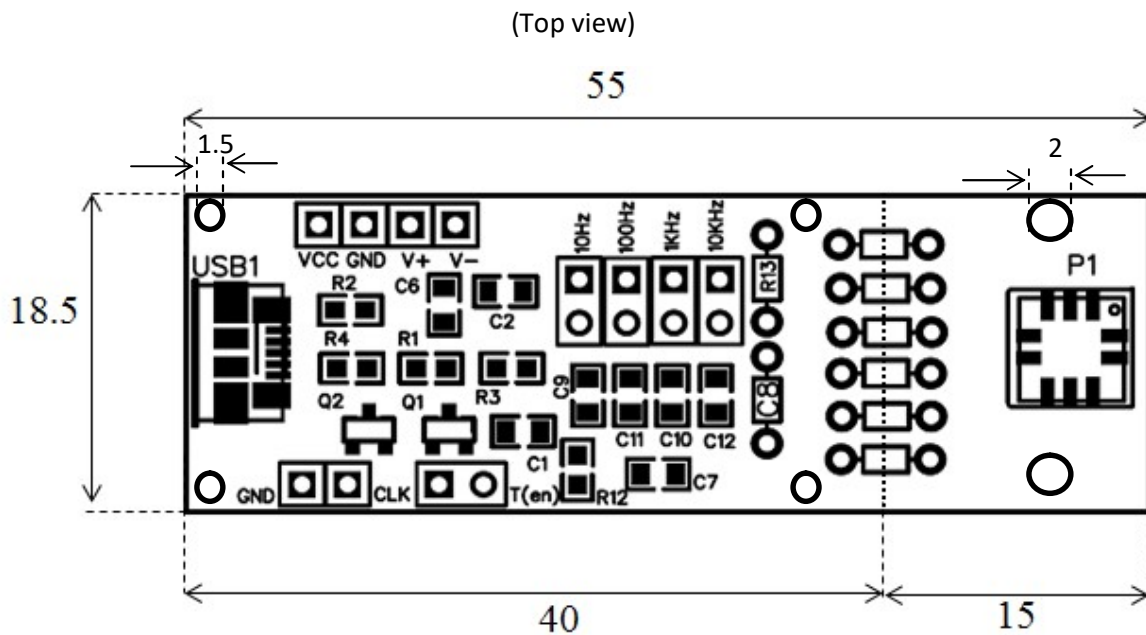

*All Dimensions are in millimeters (mm)



MULTI[™]
DiMENSION
Sensing the Future

多维科技
感知未來

American Electronic Components Inc.

1101 Lafayette Street, Elkhart, Indiana 46516, United States of America.

Web: www.aecensors.com Email: sales@aecensors.com

Toll: 888 847 6552, Tel: +1 574 293 8013

The information provided herein by MultiDimension Technology Co., Ltd. (hereinafter MultiDimension) is believed to be accurate and reliable. Publication neither conveys nor implies any license under patent or other industrial or intellectual property rights. MultiDimension reserves the right to make changes to product specifications for the purpose of improving product quality, reliability, and functionality. MultiDimension does not assume any liability arising out of the application and use of its products. MultiDimension's customers using or selling this product for use in appliances, devices, or systems where malfunction can reasonably be expected to result in personal injury do so at their own risk and agree to fully indemnify MultiDimension for any damages resulting from such applications.