



# TMR2104

Large Dynamic Range TMR linear sensor

## General Description

The TMR2104 linear sensor utilizes a unique push-pull Wheatstone bridge composed of four unshielded TMR sensor elements. The unique bridge design provides a high sensitivity differential output that is linearly proportional to a magnetic field applied parallel to the surface of the sensor package, and it provides superior temperature compensation of the output. The TMR2104 is available in 6 mm X 5 mm X 1.5 mm SOP8 and 3mmx3mmx0.75mm DFN8L package.

## Features and Benefits

- Tunneling Magneto resistance (TMR) Technology
- High Sensitivity
- Large Dynamic Range
- Low Power Consumption
- Excellent Thermal Stability

## Applications

- Magnetic Field Sensing
- Current Sensors
- Displacement Sensing
- Rotary Position Sensors

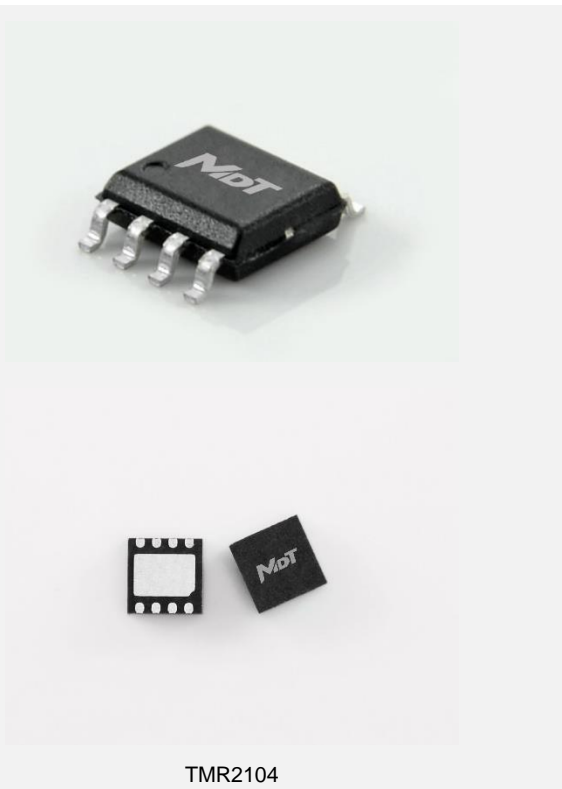

## Transfer Curve

The following figure shows the response of the TMR2104 to an applied magnetic field in the range of  $\pm 80$  Oe (left) and  $\pm 200$  Oe (right) when the TMR2104 is biased at 1 V.

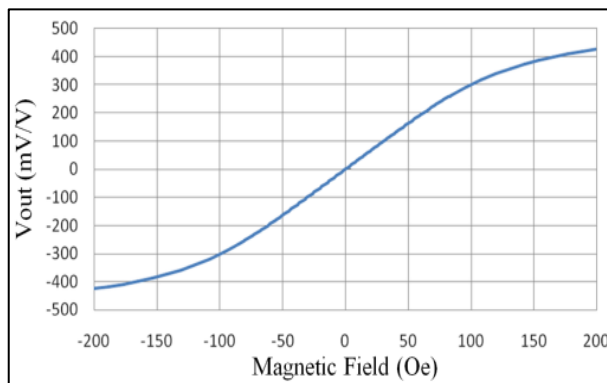
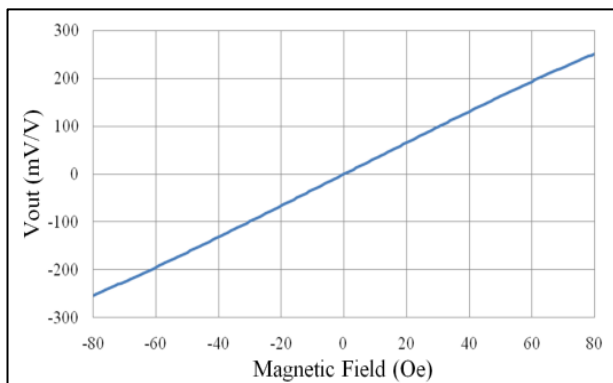

## Pin Configuration

(Arrow indicates direction of applied field that generates a positive output voltage.)

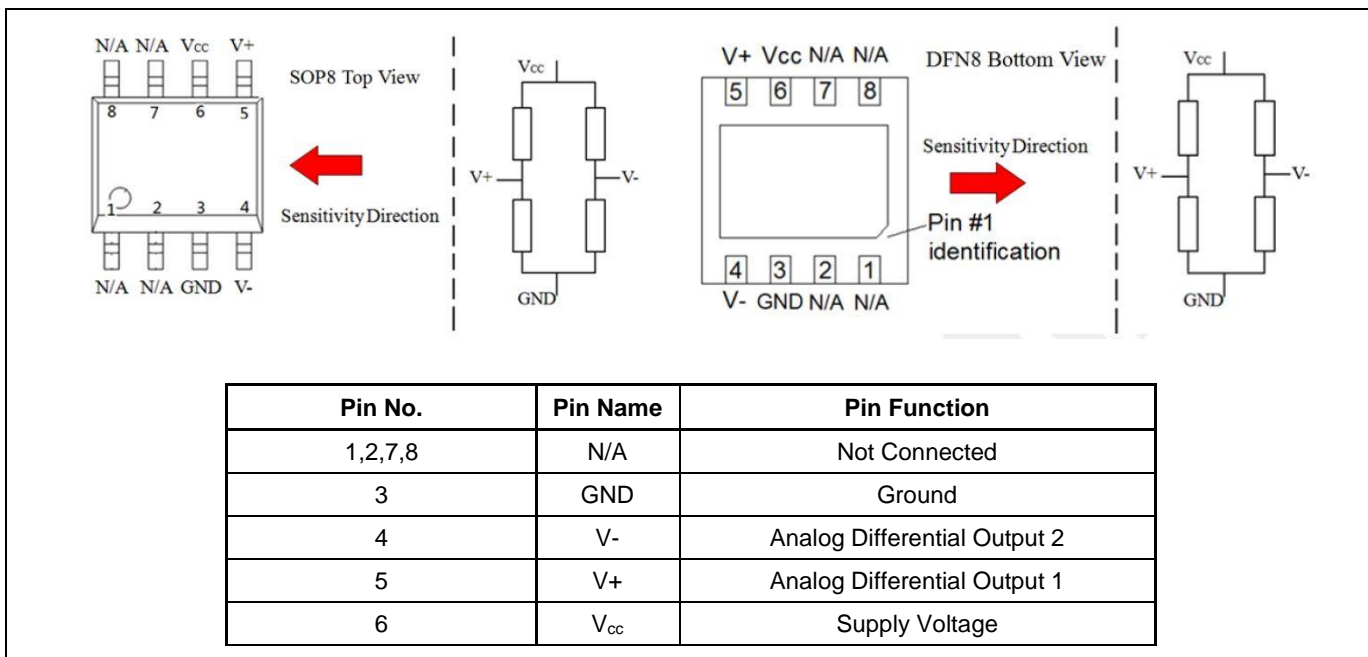

## Absolute Maximum Ratings

Parameter	Symbol	Limit	Unit
Supply Voltage	V <sub>CC</sub>	7	V
Reverse Supply Voltage	V <sub>RCC</sub>	7	V
Max Exposed Field	H <sub>E</sub>	4000	Oe <sup>(1)</sup>
ESD Voltage	V <sub>ESD</sub>	4000	V
Operating Temperature	T <sub>A</sub>	-40~125	°C
Storage Temperature	T <sub>stg</sub>	-50 ~150	°C

## Specification (V<sub>CC</sub>=1.0V, T<sub>A</sub>=25°C, Differential Output)

Parameter	Symbol	Conditions	Min	Typ	Max	Unit
Supply Voltage	V <sub>CC</sub>	Operating		1	7	V
Supply Current	I <sub>CC</sub>	Output Open		33 <sup>(2)</sup>		µA
Resistance(SOP8)	R			30 <sup>(2)</sup>		KOhm
Sensitivity	SEN	Fit @±80Oe		3.1		mV/V/Oe
Saturation Field	H <sub>sat</sub>			±150		Oe
Non-Linearity	NONL	Fit @±80Oe		1.5		%FS
Offset Voltage	V <sub>offset</sub>		-8		8	mV/V
Hysteresis	Hys	Fit @±80Oe		0.5		Oe
Temperature Coefficient of Resistance	TCR	H = 0 Oe		-600		PPM/°C
Temperature Coefficient of Sensitive	TCS			-300		PPM/°C

Notes:

(1) 1 Oe (Oersted) = 1 Gauss in air = 0.1 millitesla = 79.8 A/m.

(2) Custom resistance may be available upon request.

## Package Information

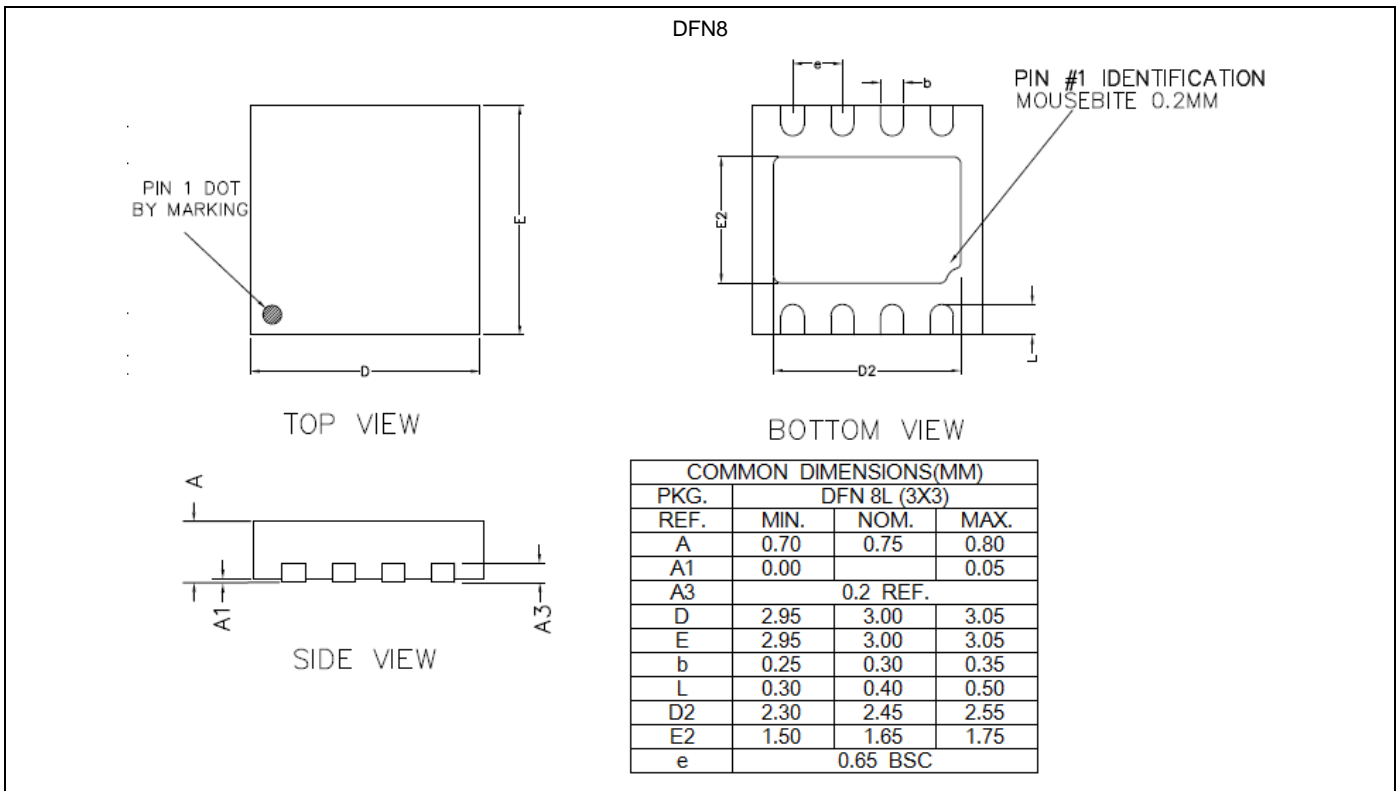
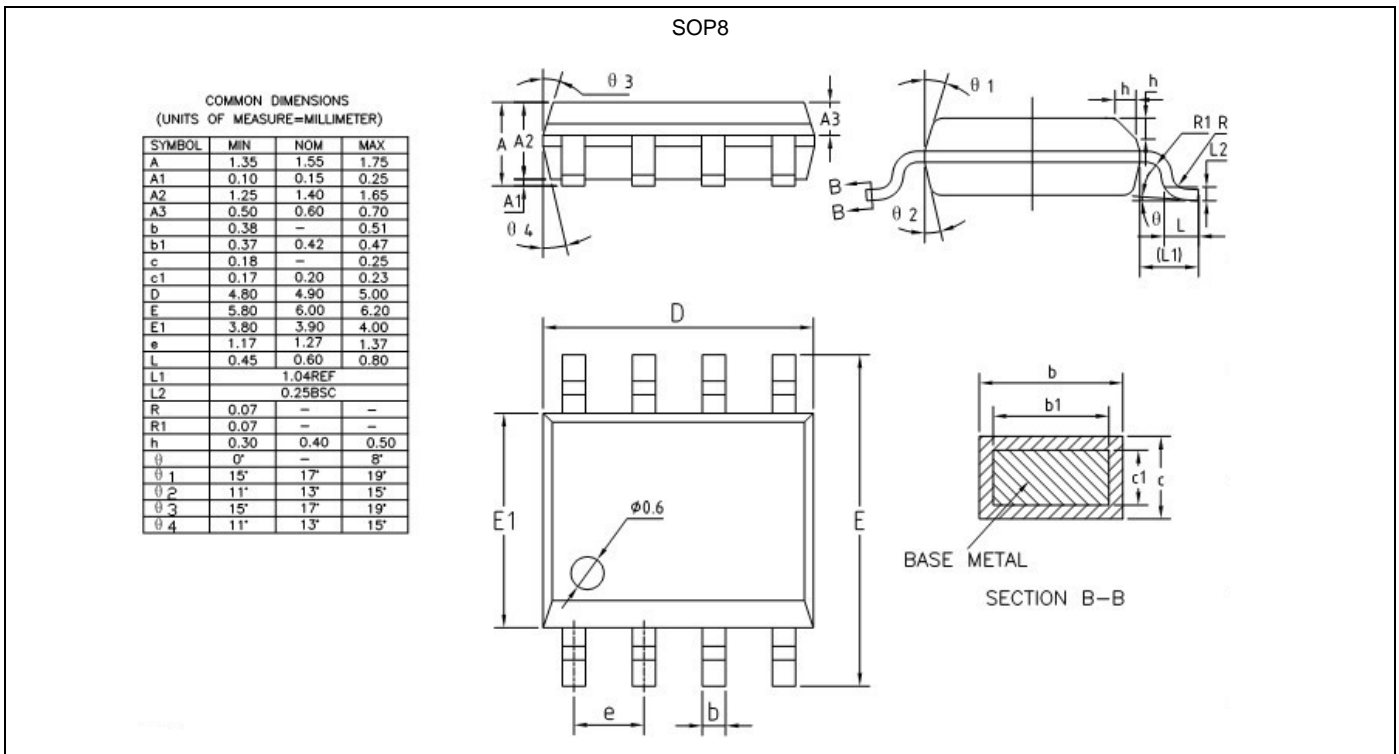

## TMR Sensor Position

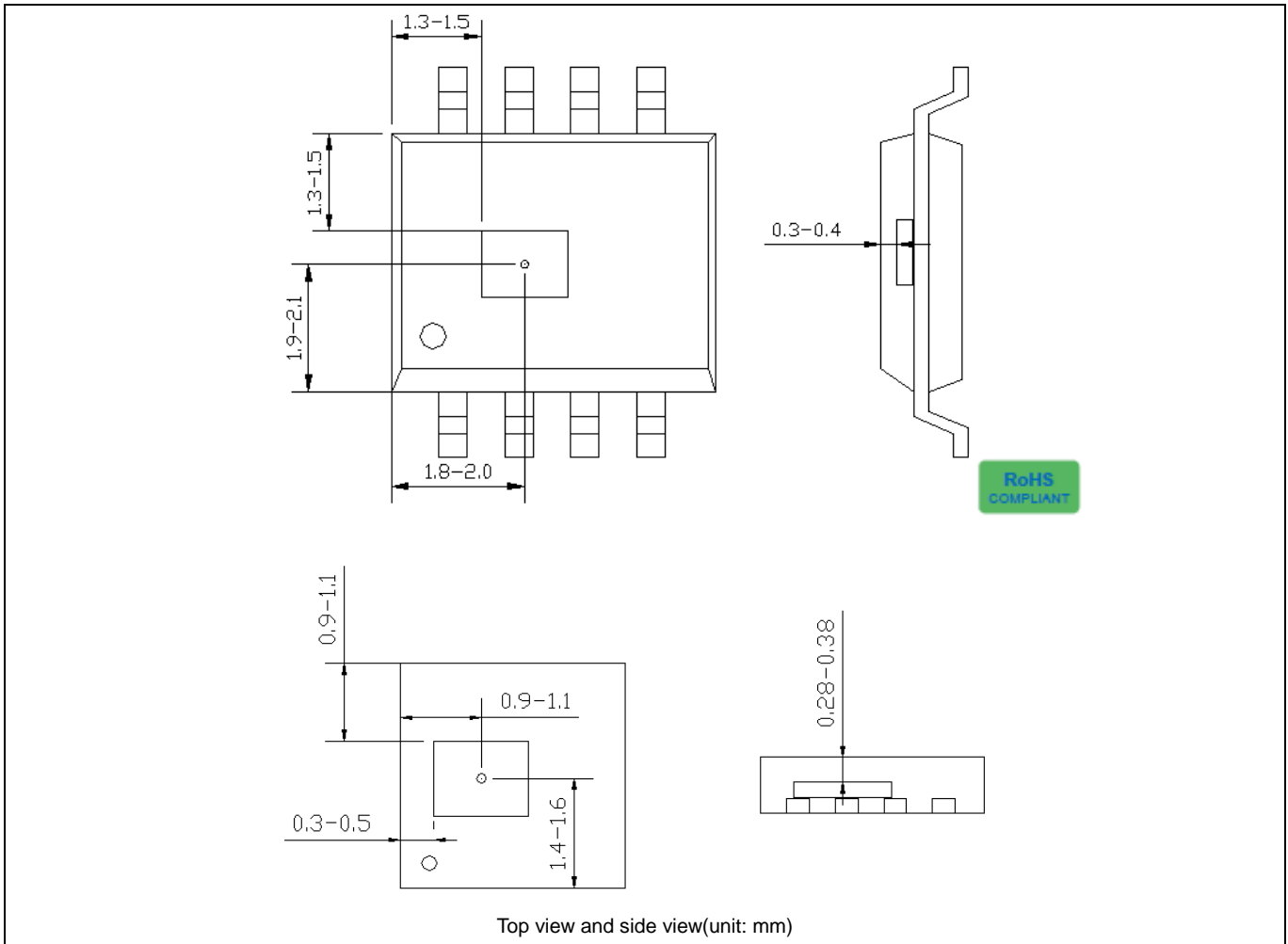

### MultiDimension Technology Co., Ltd.

Address: No.7 Guangdong Road, Zhangjiagang Free Trade Zone, Jiangsu, 215634, China

Web: [www.dowaytech.com/en](http://www.dowaytech.com/en)

Email: [info@dowaytech.com](mailto:info@dowaytech.com)

The information provided herein by MultiDimension Technology Co., Ltd. (hereinafter MultiDimension) is believed to be accurate and reliable. Publication neither conveys nor implies any license under patent or other industrial or intellectual property rights. MultiDimension reserves the right to make changes to product specifications for the purpose of improving product quality, reliability, and functionality. MultiDimension does not assume any liability arising out of the application and use of its products. MultiDimension's customers using or selling this product for use in appliances, devices, or systems where malfunction can reasonably be expected to result in personal injury do so at their own risk and agree to fully indemnify MultiDimension for any damages resulting from such applications.



**American Electronic Components Inc.**

1101 Lafayette Street, Elkhart, Indiana 46516, United States of America.

Web: [www.aecensors.com](http://www.aecensors.com) Email: [sales@aecensors.com](mailto:sales@aecensors.com)

Toll: 888 847 6552, Tel: +1 574 293 8013

The information provided herein by MultiDimension Technology Co., Ltd. (hereinafter MultiDimension) is believed to be accurate and reliable. Publication neither conveys nor implies any license under patent or other industrial or intellectual property rights. MultiDimension reserves the right to make changes to product specifications for the purpose of improving product quality, reliability, and functionality. MultiDimension does not assume any liability arising out of the application and use of its products. MultiDimension's customers using or selling this product for use in appliances, devices, or systems where malfunction can reasonably be expected to result in personal injury do so at their own risk and agree to fully indemnify MultiDimension for any damages resulting from such applications.