

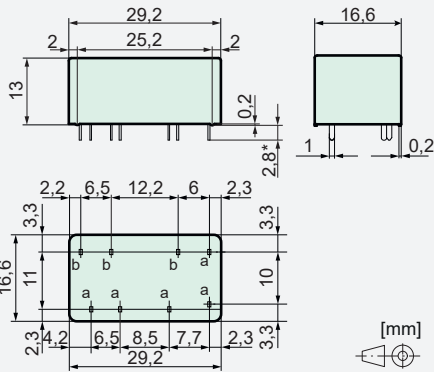

Features

- Relay with forcibly guided contacts according to IEC 61810-3, application type A
- Suitable for print mounting
- Protective separation (see insulation data)
- Contact mounting: SISF212 2 NO + 1 NC
- Small outer dimensions
- variable pin lengths on request
- Nominal coil power: typ. 0,8 W
- Coil holding power: typ. 0,25 W

Dimensions



*optional 3,8 mm

Pin dimension a	1,0 x 0,3 mm
Pin dimension b	1,0 x 0,4 mm
Recommended drilling on PCB	Ø 1,3 mm

Contact data

Contact material	AgCuNi + 0,2 ... 0,4 µm Au
Type of contact	Single contact with notched crown
Nominal switching capacity	1 500 VA (250 VAC / 6 A)
Electr. life time (0,1 Hz, rel. ED 10%)	ca. 90 000
Inrush current	30 A for 20 ms
Switching voltage range	5 ... 250 VDC/VAC
Switching current range*	3 mA ... 6 A
Switching power range*	40 mW ... 1 500 W(VA)
Contact resistance as new	≤100 mΩ / 6 V / 100 mA

*guidelines

Coil data at 20 °C

Nominal voltage (VDC)	Pick-up voltage (VDC)	Drop-out voltage (VDC)	Nominal current (mA)	Resistance (Ohm)
6,0	≤4,2	≥0,6	133	45 ± 10%
12,0	≤8,4	≥1,2	67	180 ± 10%
18,0	≤12,6	≥1,8	44	405 ± 10%
24,0	≤16,8	≥2,4	33	720 ± 10%
48,0	≤33,6	≥4,8	17	2 880 ± 10%
60,0	≤42,0	≥6,0	13	4 500 ± 13%

other voltage values on request

Circuit diagram (top view)

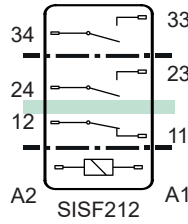

Insulation data

Double or reinforced insulation	at 250 VAC
Air and creepage distance	>5,5 mm
Test voltage	4000 V _{rms} / 1 min
Double or reinforced insulation	at 250 VAC
Air and creepage distance	>8 mm
Test voltage	4000 V _{rms} / 1 min

Test voltage: open contact*	1500 V _{rms} / 1 min
Contact opening: open contact	micro-disconnection
Creepage resistance	CTI 175
Pollution degree	2
Overvoltage category	III
Insulation resistance at Up 500 VDC	>100 MΩ

*initial value

Technical data

Mechanical lifetime	> 10x10 ⁶ operations
Switching frequency mechanical	max. 15 Hz
Response time (NO closed)	typ. 10 ms
Drop-out time* (NC closed)	typ. 3 ms
Bounce time NO	typ. 2 ms
Bounce time NC	typ. 15 ms
Shock resistance (16 ms)	NO > 17 g / NC > 10 g
Vibration resistance (10-200 Hz)	NO > 7 g / NC > 3 g
Short circuit resistance of NC contacts with pre-fuse	1 000 A SCPD 6 A gG / gL
Ambient temperature	-40 °C ... +85 °C
Thermal resistance	50 K/W
Coil limit temperature	120 °C
Weight	approx. 16 g
Mounting position	any
Mounting distance	recommendation >5 mm
Test method	A / group assembly
Protection class	RT III
Solder bath temperature	270 °C / 5 s

*without coil wiring

Tests, regulations, standards

Approvals	cULus, TÜV
UL File	E503456 Sec.1
Insulation group according to IEC 60664-1	250 VAC
Fire protection conditions	UL 94 / V-0
Standards	IEC 61 810-1, IEC 61 810-3, UL 508

Options, Accessories

none available

Product key

SISF	2	1	2	24VDC
Type designation	Number of NO contacts	Number of NC contacts	Solder terminals	Nominal coil voltage

Contact life for NO contact

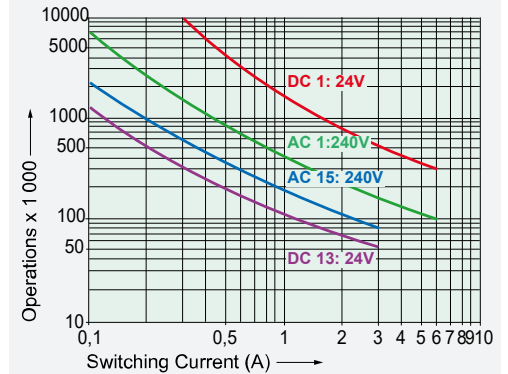

Max. switching capacity (IEC 61810-1, UL 508)

AC-1:	240 V / 6 A	B300
AC-15:	240 V / 3 A	R300
DC-1:	24 V / 6 A	
DC-13:	24 V / 3 A / 0,1 Hz	

Maximum continuous current per contact at load of:

1 contact	6 A
2 contacts	6 A

Contact load limit curve (DC)

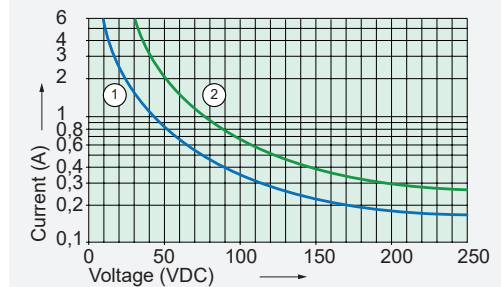

- 1) Inductive load L/R 40 ms
- 2) Resistive load

Coil excitation voltage range

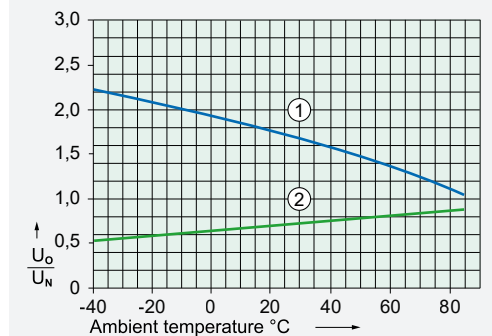

- 1) Max. excitation voltage with contact current ≤ 4 A
- 2) Min. excitation voltage without previous operation

- test conditions:

- Free-standing relay on PCB
- Duty cycle 100%