

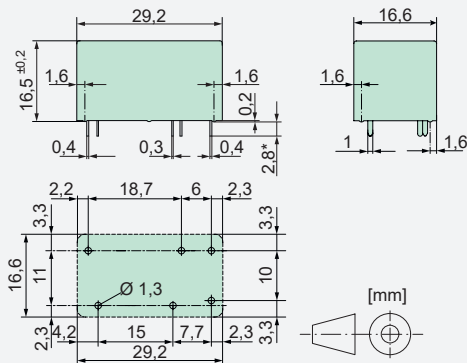

Relay Key Data

- PCB relay with forcibly guided contacts
- Protective separation between control and load circuit (leakage and creepage distances >10 mm)
- IEC 61810-3 Type A
- Double and reinforced insulation between the contacts
- Contact mounting: SIS112 1 NO / 1 NC
- Small external dimensions
- Nominal coil power 0,27 W
- Holding coil power 0,08 W
- Coils for railway applications according to EN 50 155 on request

Dimensions



*with 2,2 mm or 3,8 mm length available

Contact Data

Contact material	AgCuNi +0,2-0,4 µm Au
Type of contact	Single contact with notched crown
Rated switching capacity	250 VAC 6 A AC1 1500 VA
Electr. Life AC1 (360 S / h)	>90000
Inrush current max.	30 A for 20 ms
Switching voltage range	5 to 250 VDC / VAC
Switching current range**	3 mA to 6 A
Switching capacity range**	40 mW to 1500 W(VA)
Contact resistance (as delivered)	≤100 mΩ / 6 V / 100 mA

**Guided values

Standard coils for direct current

(other voltages on request)

Nominal voltage VDC	Min. pick-up voltage VDC at 20 °C	Drop-out voltage VDC at 20 °C	Nominal current in mA at 20 °C	Resistance in Ohm at 20 °C
5	≤3,5	≥0,5	54,9	91 ± 10%
6	≤4,2	≥0,6	46,1	130 ± 10%
9	≤6,3	≥0,9	30,5	295 ± 10%
12	≤8,4	≥1,2	23,0	520 ± 10%
18	≤12,6	≥1,8	15,2	1180 ± 10%
24	≤16,8	≥2,4	11,4	2100 ± 10%
48	≤33,6	≥4,8	5,7	8350 ± 13%
60	≤42,0	≥6,0	4,5	13100 ± 15%

Circuit Diagram (relay top view)

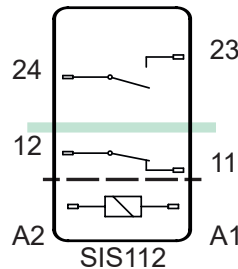

Insulation Data

- Basic insulation	at 250 VAC
- Air and creepage distance	>4 mm
- Test voltage	2500 V / 50 Hz / 1 min
- Double or reinforced insulation	
- Air and creepage distance	at 250 VAC >10 mm
- Test voltage	5000 V / 50 Hz / 1 min
Test voltage contact open	1500 V / 50 Hz / 1 min
Creepage resistance	CTI 175
Pollution degree	2
Overvoltage category	III
Insulation resistance at Up 500 VDC	>100 MΩ

Additional Data

Mechanical endurance	>10x10 ⁶ operations
Switching frequency, mechanical	15 Hz
Response time (NO closed)	typically 10 ms
Drop-out time*** (NC closed)	typically 3 ms
Bounce time of NO contact	typically 2 ms
Bounce time of NC contact	typically 15 ms
Shock resistance 16 ms	NO > 17g NC > 7g
Vibration resistance (10-200 Hz)	NO > 7g NC > 2g
Resistance to short circuiting contacts	1000A SCPD 6 A gG / gL (pre-fuse)
Ambient temperature	-40°C to +85 °C
Thermal Resistance	55 K / W
Temperature limit for coil	120 °C
Weight	approx. 18 g
Mounting position	any
Mounting distance	rec. >1 mm
Test method	A / group assembly
Type of protection	RT III
Solder bath temperature	270°C / 5 s
***without spark suppression	

Tests, Regulations, Standards

Approvals UL, cUL, TÜV	
UL File E188953	Sec. 5
Insulation class IEC 60664-1	250 VAC
Fire protection requirements	UL 94 / V0
Standards IEC 61810-1, IEC 61810-3	

Options, Accessories

DIN rail socket	
Pin length	2,2 to 3,8 mm

Product Key

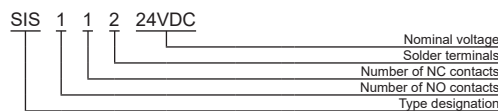

Contact Lifetime for NO Contact

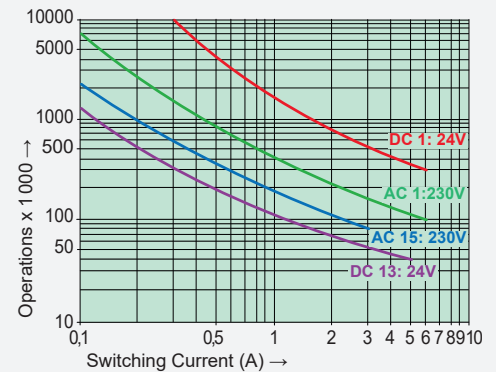

Maximal switching characteristics (DIN EN 60947-5-1)

AC 1:	250 V / 6 A
AC 15:	230 V / 3 A
DC 1:	24 V / 6 A
DC 13:	24 V / 5 A / 0,1 Hz
UL 508:	B300 / R300

Load Limit Curve with Direct Current

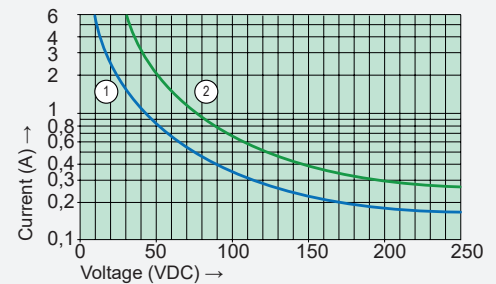

- 1) Inductive load L/R 40 ms
- 2) Resistive load

Excitation Voltage Range

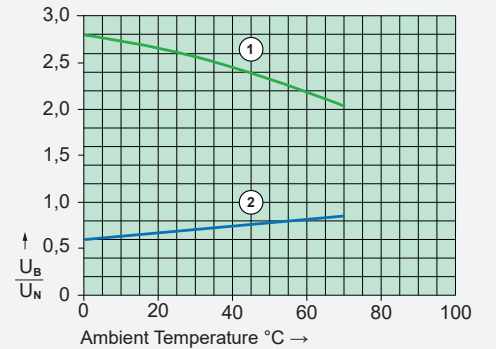

- 1) Max. excitation voltage with contact load: ≤4 A
- 2) Min. excitation voltage (guaranteed values) without previous operation

Single relay on print, no heat accumulation due to surrounding components with self-heating, duty cycle 100%.