

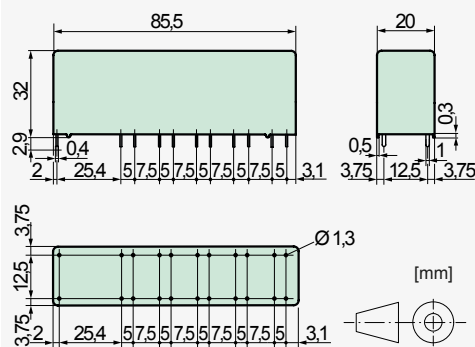

Relais Eckdaten

- Printrelais mit zwangsgeführten Kontakten
- Sichere Trennung zwischen Spule/Steuerkontakten und Ausgangskontakten (>8 mm), sowie Ausgangskontakte hintereinander (>8 mm) und linker Kontaktseite zu rechter Kontaktseite (>10 mm)
- IEC 61810-3 Anwendungstyp A
- Kontaktbestückung:
SIR282 2 AK / 8 RK SIR372 3 AK / 7 RK
SIR462 4 AK / 6 RK SIR552 5 AK / 5 RK
SIR642 6 AK / 4 RK SIR732 7 AK / 3 RK
SIR822 8 AK / 2 RK SIR912 9 AK / 1 RK
- Spulennennleistung 1,3 W
- Halteleistung 0,39 W
- Spulen für Bahnanwendungen nach EN 50155 auf Anfrage

Abmessungen



Kontaktdaten

Kontaktmaterial	AgSnO ₂ + 0,2 µm Au
Kontaktart	Kronenkontakt
Nennschaltleistung	250 VAC 10 A AC1 2500 VA
Elektr. Lebensdauer AC1(360 S / h)	ca.100000
Einschaltstrom max.	25 A für 20 ms
Schaltspannungsbereich	5 bis 250 VDC / VAC
Schaltstrombereich*	10 mA bis 10 A
Schaltleistungsbereich*	60 mW bis 2500 W(VA)
Kontaktübergangswid. (Neuzustand)	≤100 mΩ / 6 V / 100 mA

*Richtwerte

Normspulen für Gleichspannung

(andere Spannungswerte auf Anfrage)

Nennspannung VDC	Min. Ansprechspannung VDC bei 20 °C	Rückfallspannung VDC bei 20 °C	Nennstrom in mA bei 20 °C	Widerstand in Ohm bei 20 °C
6	4,2	≥0,6	218,0	27,5 ± 10%
12	8,4	≥1,2	109,0	110,0 ± 10%
18	12,6	≥1,8	72,0	250,0 ± 10%
24	16,8	≥2,4	54,5	440,0 ± 10%
48	33,6	≥4,8	27,2	1760,0 ± 10%
60	42,0	≥6,0	21,8	2750,0 ± 10%
110	77,0	≥11,0	11,8	9250,0 ± 13%
220	154,0	≥22,0	5,9	37000,0 ± 15%

Circuit Diagram (relay top view)

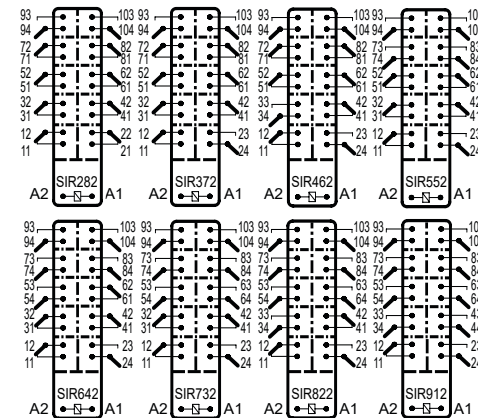

Insulation Data

- Basic insulation	at 250 VAC
- Air and creepage distance	>4 mm
- Test voltage	2500 V / 50 Hz / 1 min
- Double or reinforced insulation	at 250 VAC
- Air and creepage distance	>8 mm
- Test voltage	4000 V / 50 Hz / 1 min
Test voltage contact open	1500 V / 50 Hz / 1 min
Creepage resistance	CTI 250
Pollution degree	2
Overvoltage category	III
Insulation resistance at Up 500 VDC	>100 MΩ

Additional Data

Mechanical endurance	>10 x 10 ⁶ operations
Switching frequency, mechanical	15 Hz
Response time (all NO closed)	typically 18 ms
Drop-out time** (NC closed)	typically 5 ms
Bounce time of NO contact	typically 8 ms
Bounce time of NC contact	typically 12 ms
Shock resistance 16 ms	NO > 10g NC > 6g
Vibration resistance (10-200 Hz)	NO > 8g NC > 2,5g
Resistance to short circuiting contacts	1000 A SCPD 10 A gG / gL (pre-fuse)

Ambient temperature	-40°C to +70°C
Thermal Resistance	40 K / W
Temperature limit for coil	125°C
Weight	approx. 60 g
Mounting position	any
Mounting distance	rec. >5 mm
Test method	A / group assembly
Type of protection	RT II
Solder bath temperature	270°C / 5 s

**without spark suppression

Tests, Regulations, Standards

Approvals	
UL File E188953	Sec. 3
Insulation class IEC 60664-1	250 VAC
Fire protection requirements	UL 94 / V0
Standards IEC 61810-1, IEC 61810-3	

Options, Accessories

none available

Product Key

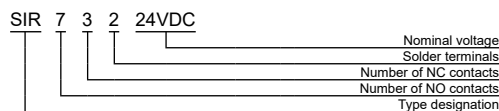

Contact Lifetime NO Contacts

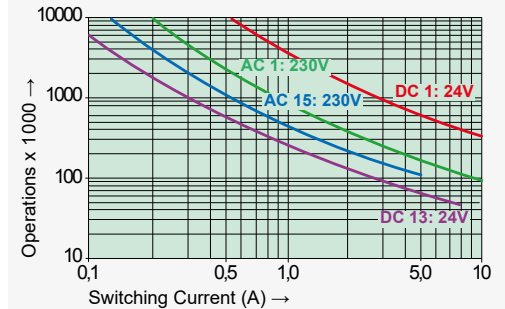

Maximal switching capacity (DIN EN 60947-5-1, Tab. C2):
AC 15: 230 V / 5 A
DC13: 24 V / 7,5 A / 0,1 Hz
UL 508: C600 / R300

Maximal contact load at AC 1 with 230 V:

- 2 contacts with 10 A each
- 3 contacts with 8,4 A each
- 4 contacts with 7,3 A each
- 5 contacts with 6,5 A each
- 6 contacts with 6 A each
- 8 contacts with 5 A each
- 9 contacts with 4,2 A each

Load Limit Curve with Direct Current

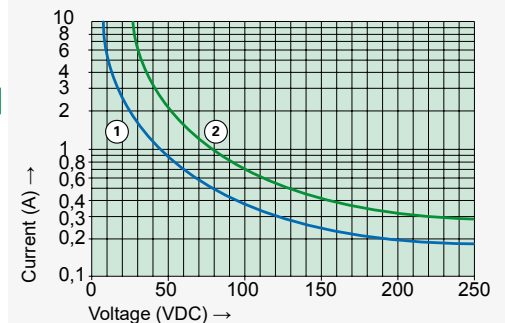

- 1) Inductive load L/R 40 ms
- 2) Resistive load

Excitation Voltage Range

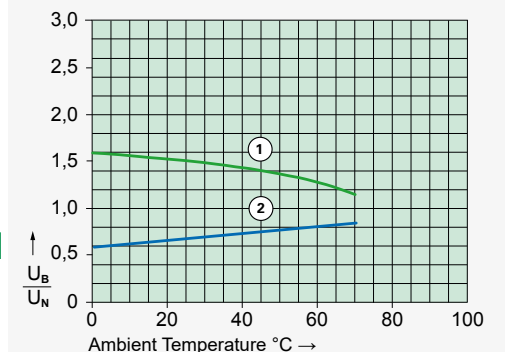

- 1) Max. excitation voltage with contact load: ≤ 6 A
- 2) Min. excitation voltage (guaranteed values) without previous operation

Single relay on print, no heat accumulation due to surrounding components with self-heating, duty cycle 100%.