



PCB version pictured

- High current automotive or industrial relays
- Ideal for DC Motor Control and lamps, fans, winch & sunroof motors, vehicle alarms
- Sn Plated, copper terminals for high continuous DC current capacity
- Industry standard Maxi-ISO terminals
- PCB Versions available

ROHS Compliant ✓

### Contacts

Contact arrangement	SPST-NO (1 Form A)
Contact material	AgSnO <sub>2</sub>
Max. switching voltage	DC 75VDC -current dependent. >24VDC Contact factory
Contact rating (resistive)	70A (14(VDC), 20A 24(VDC))
Max. switching current (inrush)	make 120A
Rated power	980W
Min. switching current	100mA / 6VDC
Initial contact resistance	≤30mΩ, max. at 0.1A/6VDC (IEC 61810-7 / 4.12)

### Coil

Rated voltage	DC 6V, 12V, 24V
Operating range of supply voltage	See coil table 1
Rated power consumption	2.3W (2.5W with resistor)

### Insulation

Insulation resistance	100MΩ at 500VDC, 50%RH, 25°C (IEC60255-5 / Item 7)	
Dielectric strength	coil to contact	500Vrms / 1 min (IEC 60255-5 Item 6)
	contact to contact	500Vrms / 1 min (IEC 60255-5 Item 6)

### General Data

Operating time	ms	≤7
Release time	ms	≤5
Electrical life	ops.	1 x 10 <sup>5</sup> (IEC61810-7 / Item 4.30)
Mechanical life	ops.	1 x 10 <sup>7</sup> (IEC61810-7 / Item 4.31)

### Environmental

Environmental protection	IP54 Dust cover, IP67 Fully sealed (optional)	
Ambient temperature	operating	-40 to 105°C (Derate above 85°C - consult factory)
	storage	-40 to 155°C
Shock resistance	functional	30m/s <sup>2</sup> 6ms
	destructive	196m/s <sup>2</sup> (20g)
Vibration resistance	DA 1.8mm, 20 to 500Hz	
Dimensions	L x W x H	26.5 x 26.5 x 25.2mm (excluding terminals)
Weight	approx.	36g depending on style and mounting

### Ordering Code

D G 5 6 C - 7 0 2 1 - 3 5 - 1 0 2 4 - D R

Series C = 70A

High current

Contact material

70: AgSnO<sub>2</sub>

Contact configuration

21: SPST-NO

(1N/O, 1 Form A)

Environmental protection

3: Sealed cover IP67

7: Dust cover IP54

9: Dust cover with plastic mounting bracket

Mounting & terminations

5: For PCB

6: Flat blades

Coil options

Blank: No options

R: Parallel resistor

D: Parallel diode +85, -86

DR: Parallel diode -85, +86 (standard for diode)

DD: Double diodes +86 (see fig. 2 for detail)

Coil code:

See table 1

DC Coil Data						Table 1
Coil code	Nominal voltage (VDC)	Coil resistance (Ω) ± 10%	Must operate voltage max. (VDC)	Must release voltage min. (VDC)	Coil power consumption (W)	Parallel Resistor (Ω) ± 5% (when fitted)
1006	6	15.7	3.6	0.6	2.3	180
1012	12	62.0	7.2	1.2		680
1024	24	250.0	14.4	2.4		2700

### Dimensions mm

Fig. 1

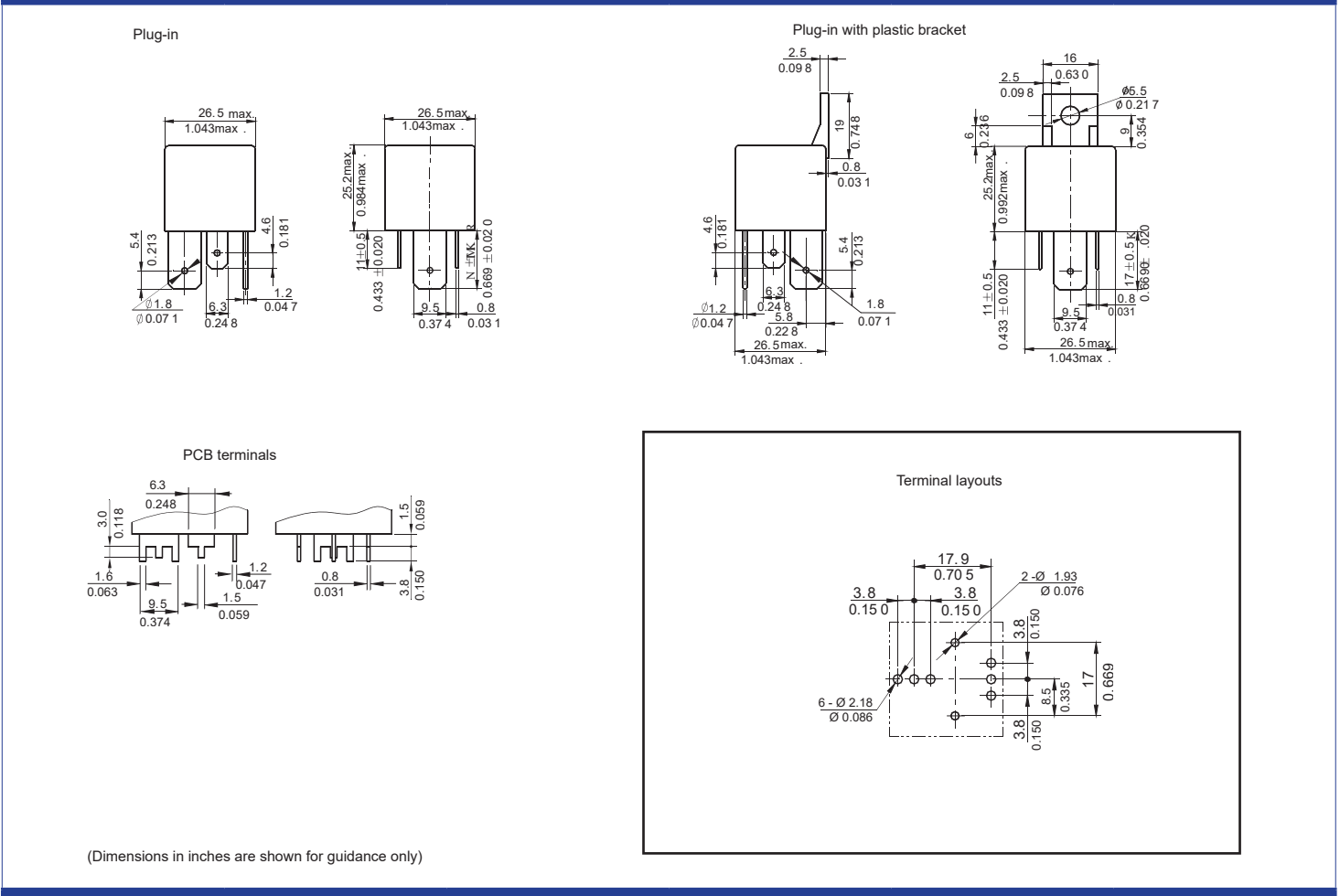

### Connection diagrams

Fig. 2

